

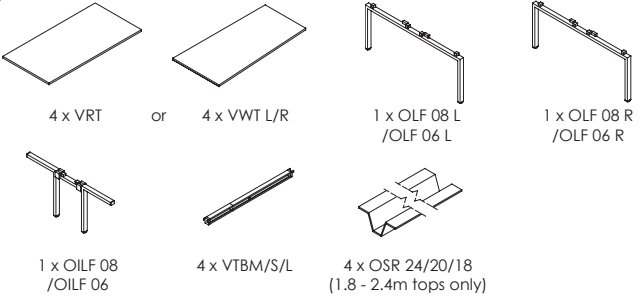

4+ unit back to back Oblique Visual bench using the following tops:

OVRT 0806/1006/1206/1208/1408/1608/1808/2008/2408  
OVWT 1208/1408/1608/1809/2009/2409

				<p>Fixings (numbers based on a 2 unit bench)</p>  <p>8 x 5mm x 85mm hex bolts 4 x 5mm x 55mm hex bolts</p>  <p>40 x 6mm x 26mm mushroom head screws (1.8 - 2.4m tops)</p>		<p>Equipment Required (not included)</p>  <p>4 mm Allen key Rubber mallet</p>	
---	--	--	--	--	--	--	--

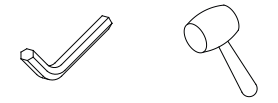
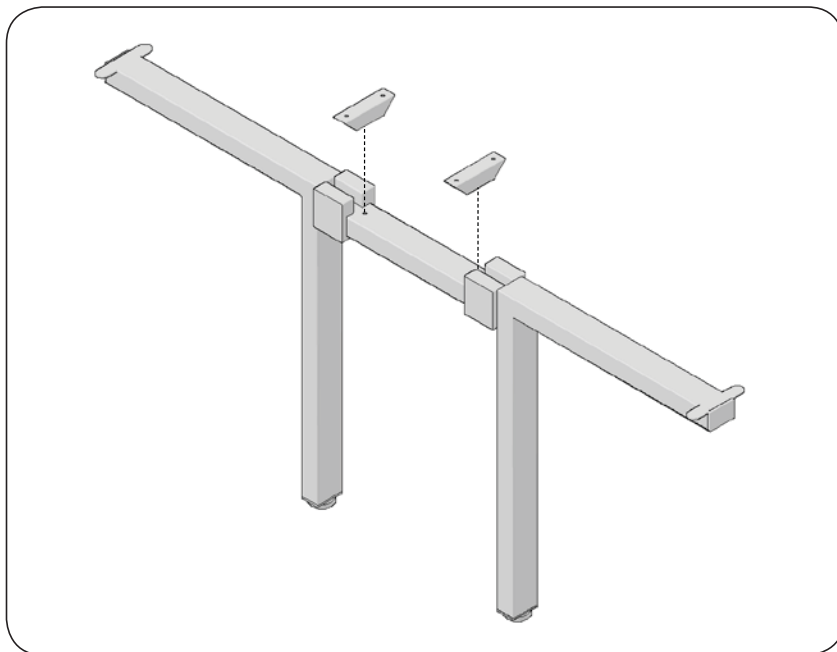

To start with assemble the intermediate leg in its entirety; take the leg along with the two wedge shaped spacers and two 55mm bolts. Insert the bolts up through the holes in the leg frame and into the threaded holes on the underside of the spacers. Tighten them so they are secure but do not over-tighten. You should not have to use excessive force to tighten the bolts adequately.

With the intermediate leg assembled, take one of the beams and insert into the leg's bracket as shown by slotting in and sliding down. The gap in the beam should face towards the rear of the desk i.e. the side which it is nearest to.

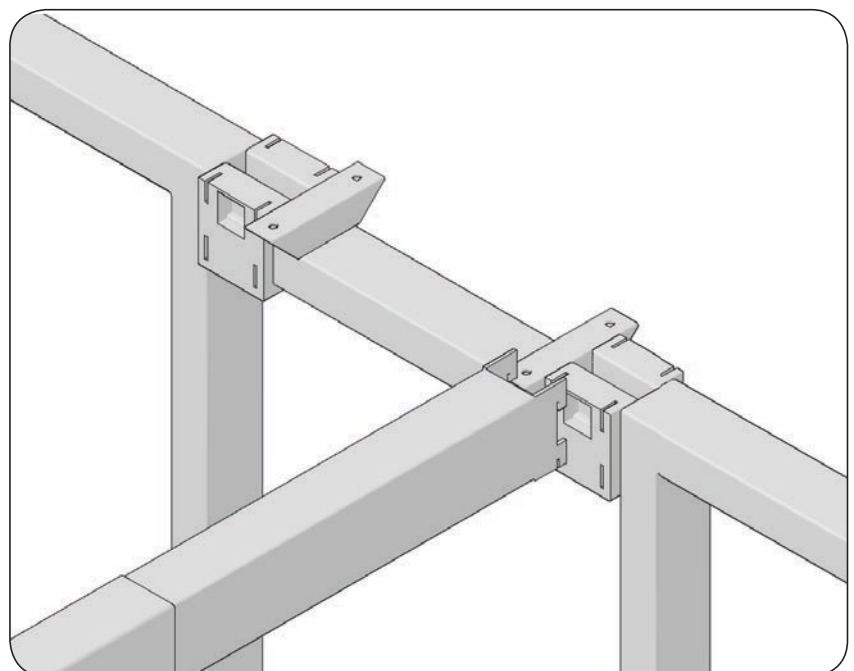

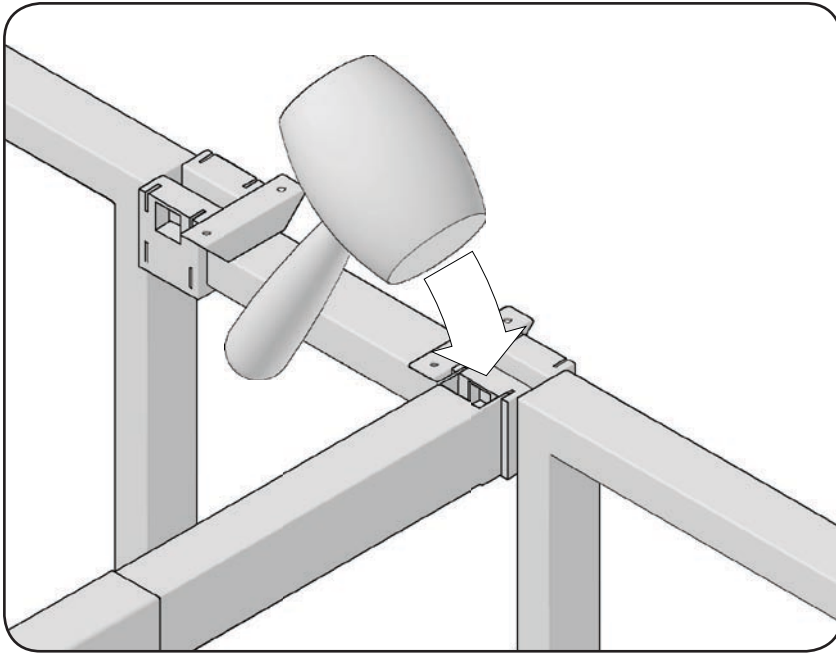

Using the mallet secure the end of the beam fully into the intermediate leg by tapping at the end so as not to damage the top of the beam.

Repeat steps 2 & 3 fixing the beam into one of the end legs. Once this is complete repeat the whole process with the other beam that runs between the legs (parallel to the one just placed).

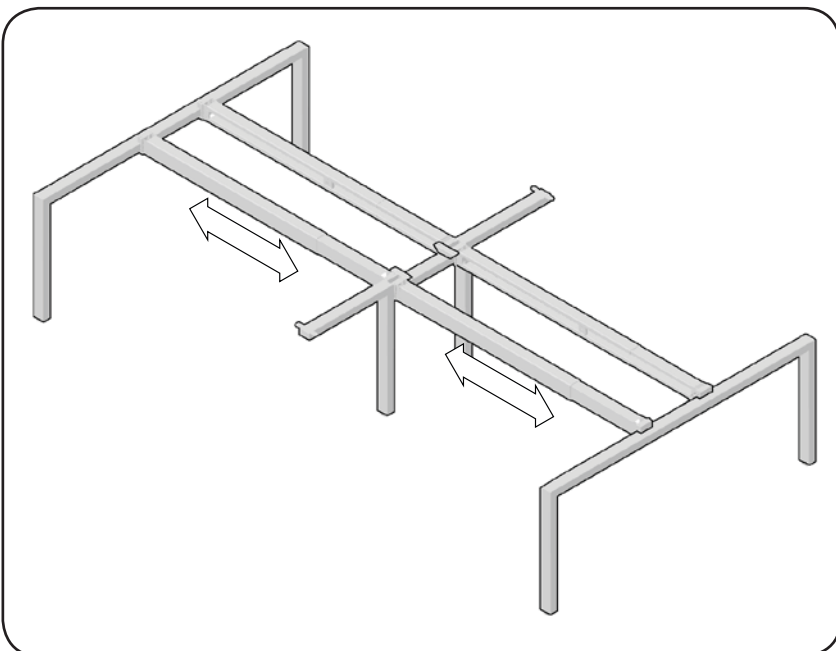
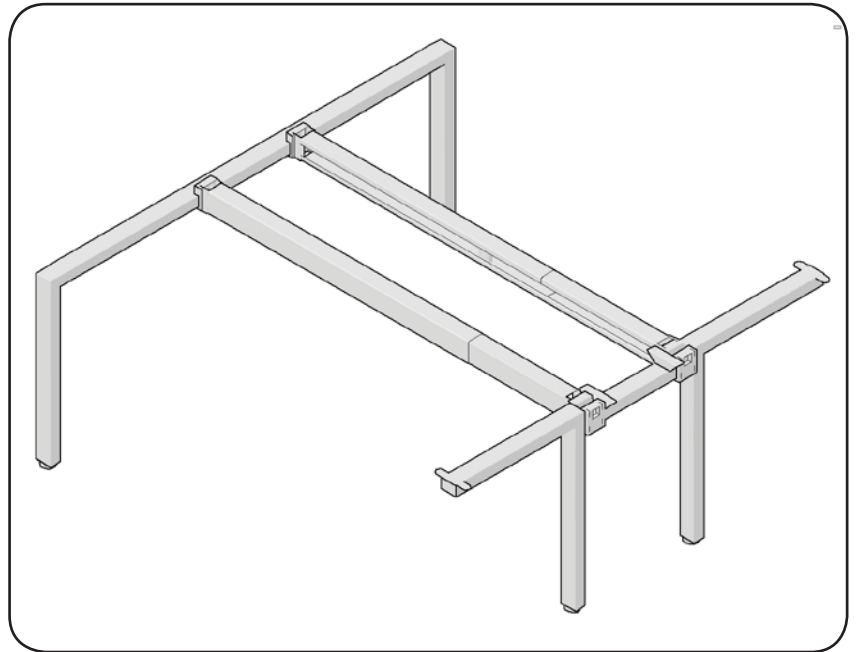

Repeat steps 2 to 4 with the remaining legs and beams. If your bench consists of multiple units just keep adding the sections one by one. It is advisable to build up the frame in this way so it is in the desired position for the finished bench as large benches can be difficult to move.

Your assembled frame should look like this (or with as many sections as your bench consists of). With the bracket in the centre of each beam loosened adjust each frame to roughly fit the width of each top using a tape measure or top placed in front on the frame to check the width. The tops will extend to the centre of each intermediate leg.

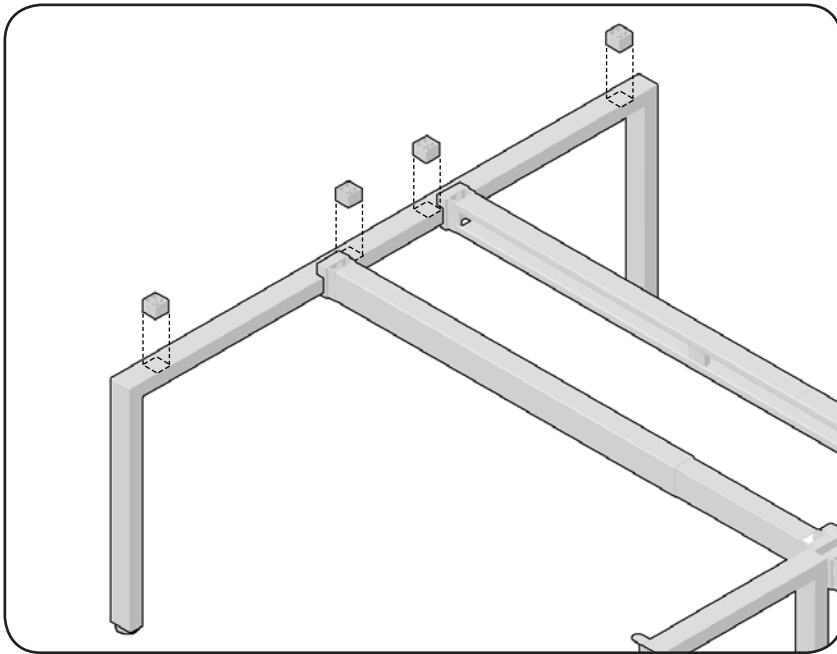

Take the four plastic spacers supplied with the legs (two with each leg) and place one over each of the holes in the leg frame, aligning the holes in each spacer roughly with the corresponding hole in the leg. The spacer has a small lip which should fit over the radius on the edge of the leg.

*Note: this step is only for tops with a support rail only i.e OVRT 1808/2008/2408.*

With the desk top turned upside-down, align the support rail with the corresponding pilot holes and screw into position using the 6mm x 26mm mushroom head screws provided (10 for each top).

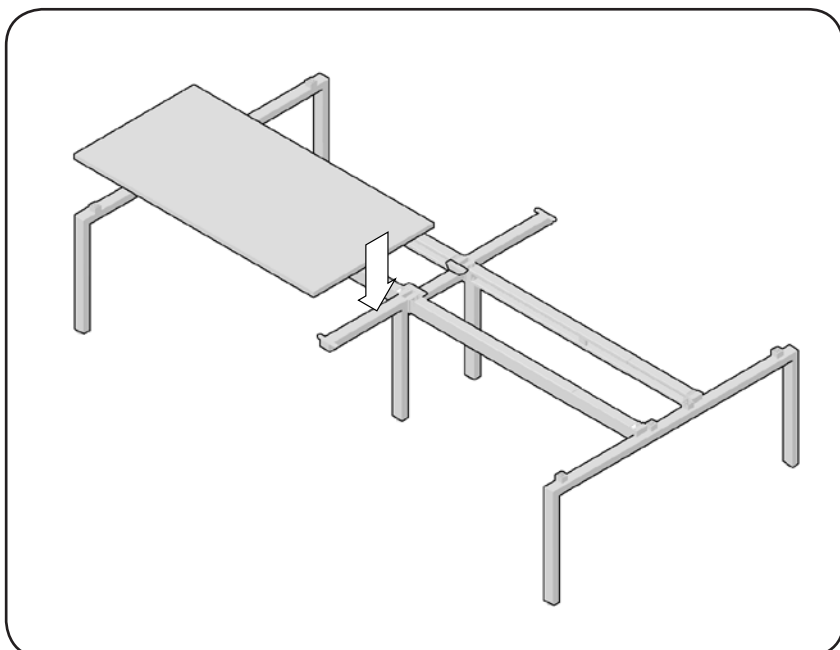
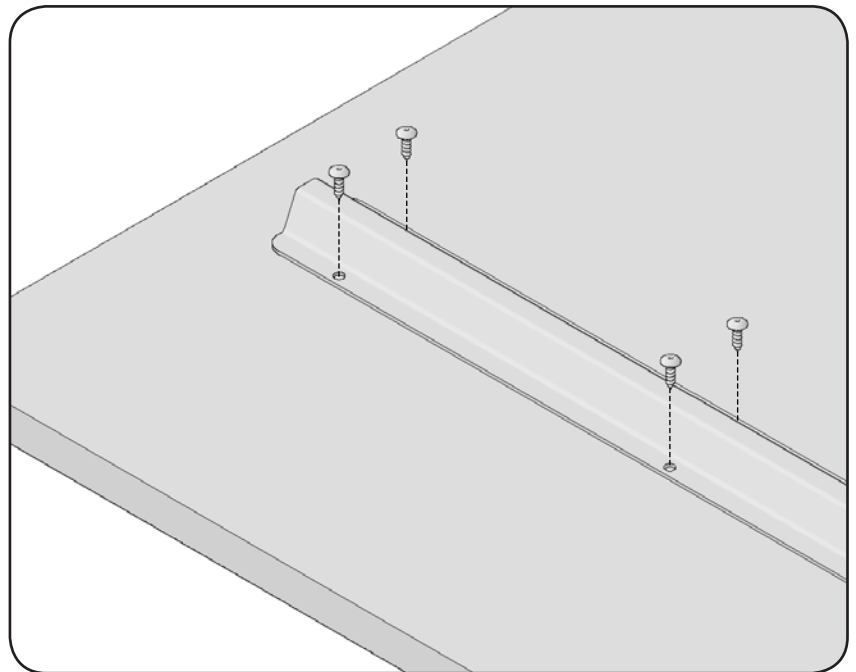

If you are fitting screens or 2nd level storage to your bench, please refer to additional instructions at this point, before fixing the tops on.

With the assistance of at least 1 other person, gently lower the top into position over the frame, resting it on the spacers and the beam. Once the top is in position, line up the outside leg more accurately with the end of the desk top taking care to avoid knocking the spacers out of position.

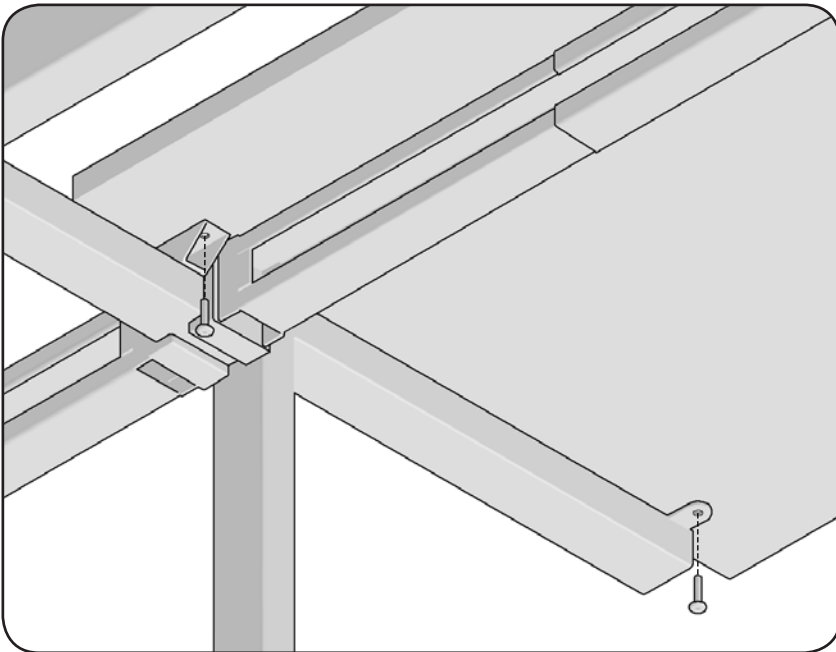

Using two 15mm bolts secure the top to the intermediate leg by placing them through the holes in the wedge shaped spacer and the hole in the front of the cutback leg, into the underside of the desk top. Fully tighten these bolts.

Now insert one of the 5mm x 85mm bolts through the bottom of the end leg frame, through the spacer, into the bottom of the desk top. You may need to shift the leg slightly in order to get the bolt through and into the desk top. Screw in far enough that the bolt holds itself in position and repeat with the leg frame's other bolt. Once both bolts are in position fully tighten them. Once the top is secured, fix the beam by tightening the bracket in the centre of the beam using a 4mm Allen key.

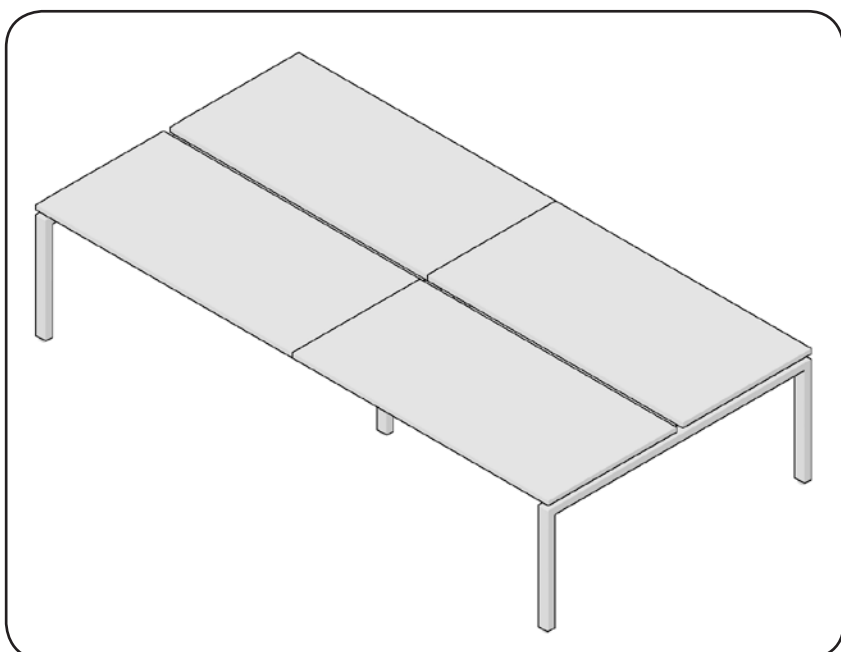
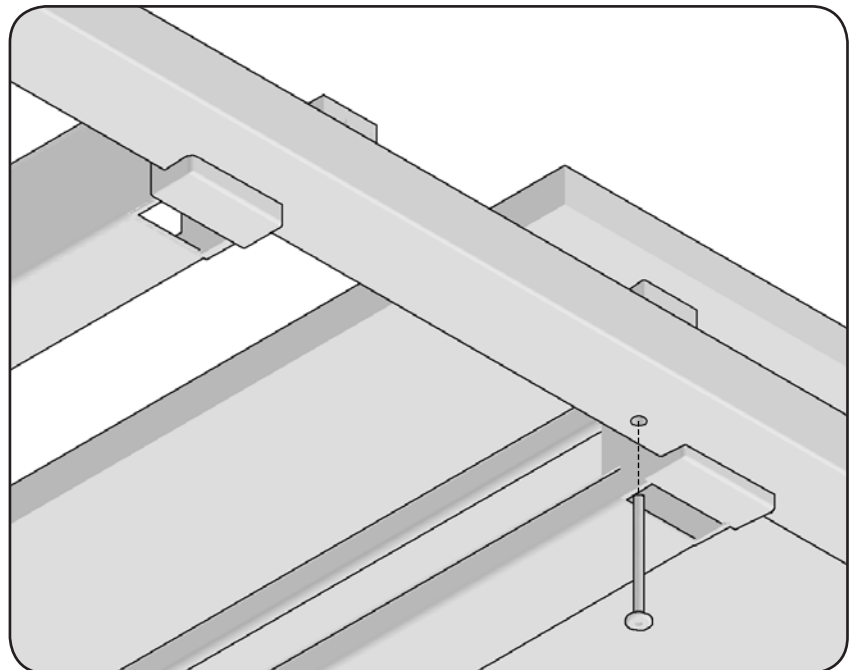

Repeat the previous 5 steps using the remaining leg frame, or if your bench consists of multiple tops, keep working along its length in this way ensuring all fixing bolts are securely tightened.

Your finished bench should resemble the image on the left. Please refer to further instructions for the fitting of screens and accessories.